

Implementation on Modeling and Analysis of Multi Stage with Multi Phase DC-DC Boost Converter

Mukesh Kumar, Manoj Kumar Dewangan, Maheedhar Dubey

Department- Electrical Engineering, VEC Lakhanpur, Chhattisgarh Swami Vivekanand Technical University, Bhilai-Durg (C.G.), India

Article Info

Article history:

Received 2 February 2021

Received in revised form

28 February 2021

Accepted 5 March 2021

Available online 15 March 2021

Keywords: Boost Converter, High Voltage, DC-DC Converter.

Abstract: In this paper, a new version of the new Hybrid Boost DC-DC ready to draw power from two different DC sources for standard DC-bus feeds is presented. An important feature of the proposed converter is that both sources provide simultaneous power to a lower load than the reduced current rate. This feature is very attractive for DC grid applications. With the analysis of the time zone, steady-state performance is established and the transformational power correction parameters are obtained. In this paper, a powerful converter is introduced, with its operating principles based on charging pumps and converters of reinforcement series. In addition, although three switches are used, no separate gate driver is required instead of one bridge gate driver and one gate driver on the lower side. As such, the proposed converter is easy to analyze and easy to operate. In addition, additional test results are provided to confirm the effectiveness of the proposed converter.

1. Introduction

In order to the high-voltage boost converters are widely used in the industry, the integration of renewable energy distribution systems based on renewable energy such as fuel cells, solar cells, batteries etc. [1-2], has made rapid progress in the modern era. A wide range of electrical power will be available from low power sources and this area is attracting the attention of many investigators, therefore, in order to obtain high power, a step-up DC-DC converter is required in the advanced phase. The standard amplifier converter is able to provide output power output, when it comes to applications that require power amplification when output, the converter must be over-operating, say the 0.9 scale when the converter is up. The problem of a performance converter that operates below the extremely poor performance rate impairs efficiency, imposes barriers to short-term response, and the need for a faster and more cost-effective measure [3]. Therefore to address the needs of such applications many of the topological modifications are introduced into existing DC-DC converters, such as switching diode capacitor cells and switching Inductor cells based on hybrid variables, incorporating inductor reciprocating cells, etc. It has been tested and reported in literature [4-7]. Therefore, a diode and cross-capacitor-based hybrid boost converter capable of operating under large scale-ups and providing additional power output [8-13].

Although these converters have simple operating principles [14-16], their power conversion rates are very low. In [17] and [18], the voltage-lift process is used to achieve a power boost, but the values associated with the conversion of electrical energy are not so high. In [19] - [22], although power conversion rates may increase by increasing the number of energy-efficient cells, additional material or active floating switch is required, thus making all circuits more complex and individual drivers more required.

A high-voltage boost boost, based on two-charge pumps with only two switches used and a series switches with only one switch used, is introduced, using two pump capacitors and two inductors to achieve power boost. It is known that the conductor of two inputs resembles an inductor in a traditional amplifier converter except that these two inductors and two pump capacitors charge their stored power out of the series. In addition, you do not need a remote gate driver instead of a single and 1 bridge gate driver the driver of the gate on the lower side. In this paper, a brief overview of the functionality of such a converter is provided and more test results are provided to confirm its effectiveness.

1.1 Objective

Multi-phase booster converter, which is the topology chosen for boosting Inverter design, circuits must be mathematically analyzed, designed and maintained Simulated to verify the desired result.

Corresponding Author,

E-mail address: netamengg@gmail.com

All rights reserved: <http://www.ijari.org>

Appropriate feed-back control method the load must be applied to produce the desired output despite the variation in the input voltage and any other converter parasitic effect. It should be after the booster circuit is designed Cascaded with inverter for DC-AC conversion. Need simulation include a loss factor such as the DC resistance of the inductor, the equivalent series resistance on the resistance of the capacitor and power semiconductor switch. Small signal of multi-phase and multi-stage boosters is required for AC modeling to assess its stability and design a control system.

2. System Methodology

A novel approach to achieving maximum static gain on an undivided dc-dc converter is presented in this concept. A common lifting converter has been developed to increase power to a higher level and the first few stages have multiple components to avoid high current pressure on the switch. Multi-phase configuration can significantly reduce inductor current and voltage effect due to the operation of the same phases and related phases, thereby reducing the filter size. The operating principle and the construction process are presented in various phases, Multi-Stage and Multi-Phase integrated

Multi-Stage converter. The main application of the Multi-Phase Multi-Stage booster has been identified as being in a battery sourced Inverter design, which replaces the step-up transformer.

With the growth of a battery-powered app, there is a great need for better performance, smaller size, lower cost and higher step dc-dc converter. Typical applications are a hybrid vehicle, uninterrupted power supply and a renewable energy system such as solar. The climbing stage is generally a critical point for the construction of highly efficient transformers due to the input performance of high input and output power, so detailed research is done, in order to define the local foundation for high performance action. An integrated magnetic converter such as a flyback or push-pull converter can be used to achieve maximum static gain. However, the volume of the power transformer will greatly affect the size of the converter. Leak inductance can produce energy pressure; high frequency switching will reduce the efficiency of the transformer itself and will create electromagnetic interference (EMI), thereby reducing the efficiency of the converter. A conventional renewable converter, which can offer a high rise power gain but with high power charge and current pressure on semiconductor switching, high performance cycle performance.

The concept includes stable condition analysis, small signal modeling and closed loop control of the Multi-Stage Multi-Phase boost booster converter with the Type III compensator used. All variations in modeling, modeling and construction are taken into account the transformer effect effects such as copper loss and semiconductor loss. The sequence of integrated switches is discussed with the phase three converter. High frequency Inverter charging performance discussed when Inverter acts as a rectifier

and booster in buck mode. Multi-Phase Multi-Stage booster designed to be validated with MatLab / Simulink.

3. DC-DC High Voltage Boost Converter

The step-up stage normally is the critical point for the design of high efficiency converters due to the operation with high input current and high output voltage, thus a careful study is required in order to define the topology for a high step-up application [8]. From the section 1.3, with High Frequency Link Inverter, to reduce size and weight of the transformer the switching frequency of the converter was increased, but it ended with switching losses and the design of a customized highly efficient transformer is too difficult [3]. To avoid switching losses, resonant converter2 and the DC Link inverter topology were chosen, but it too ended with inefficiency in implementation. Thus, there is need for an alternate booster, which doesn't incorporate transformer as boosting component. As per the thumb rule used for the design of conventional boost converter, the voltage cannot be stepped up more than four times the input voltage, i.e. the maximum duty ratio allowed is 0.75. For very high static gain in conventional boost converter, the switch is stressed by very high input current during ON period of switching cycle and very high output during OFF condition. The booster should be of small size, highly efficient, and be easy in control on load variations.

3.1 Boost Converter With Voltage Multiplier Cell

The conventional boost converter is used along with voltage multiplier circuit to step up the voltage to a very higher level [2]. The Figure 6-1 below shows a boost converter cascaded with the voltage multiplier cell. For very high static gain many such voltage multipliers can be cascaded. The basic concept is to use a voltage doubler circuit composed of diodes and capacitor, as one multiplier cell.

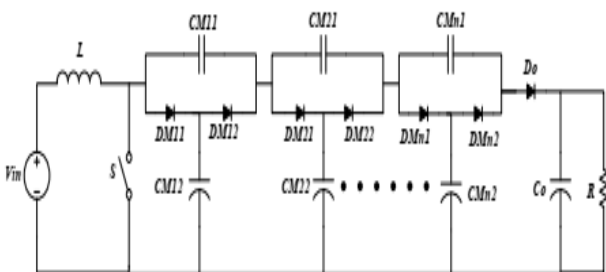

Fig. 1: Boost Converter with Voltage Doubler Circuit

For a boost converter, composed of M cascaded voltage multiplier circuit, the output voltage will be multiplied by the factor (M + 1). Thus the static gain of the proposed converter is given by, For a boost converter, composed of M cascaded voltage multiplier circuit, the output voltage will be multiplied by the factor (M + 1). Thus the static gain of the proposed converter is given by,

$$q = \frac{V_o}{V_{in}} = \frac{(M + 1)}{(1 - D)} \tag{i}$$

Where, M - number of voltage multiplier cells
D - Duty cycle the nominal duty cycle is defined by,

$$D = \frac{V_o - V_{in}(M + 1)}{V_o} \tag{ii}$$

Considering the project, the first stage booster has to boost the voltage from 12V battery to around 380V to 400V. It results the static gain of 32 and the max duty ratio allowed as per thumb rule is 0.75. Thus, the number of voltage multiplier stages required is 8. It does not replicate a good design to have boost converter with 8 voltage multiplier stages. For the inverter used in On-line UPS, the settling time is very critical but the inverter incorporating boost converter with voltage multiplier cell takes more time to settle to its final voltage level.

3.2 Multi-Stage Boost Converter

It is a novel approach where a cascaded boost converter results in the output voltage increasing in a geometric progression that to with a simple structure [10].

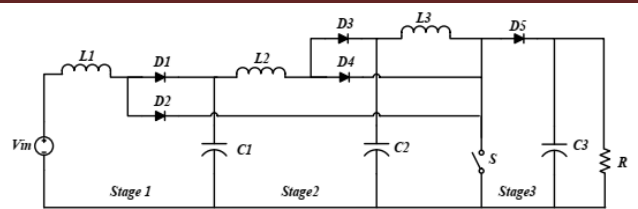

Fig. 2: Multi-Stage Boost Converter with single switch

This converter topology suits much better for boosting the voltage from 12V battery to around 380V with the duty ratio of less than 0.7. In the case with high step- up static gain, as the voltage level is raised to higher level correspondingly the input current too raises to a high level, power equality [11]. Thus, with the Multistage Boost converter discussed, the high input current has to flow through the switch S and it proves to be stress on it. So a slight variation in the converter can be made by replacing the diode D2 and D4 with switch S1 and S2 and connecting to the ground.

3.3 Multi-Phase Boost Converter

To avoid high current stress on the switch and inductor of the boost converter, the conventional boost converter can be multi phased, thus higher efficiency is ensured [1, 7]. The multi-phase booster can be achieved by adding more parallel legs to the conventional boost converter [28-29]. The Figure 6-4 below shows a threephase boost converter, where two more legs are connected in parallel with the conventional one. A suitable algorithm is required for control switches to achieve the interleaved switching sequence [6].

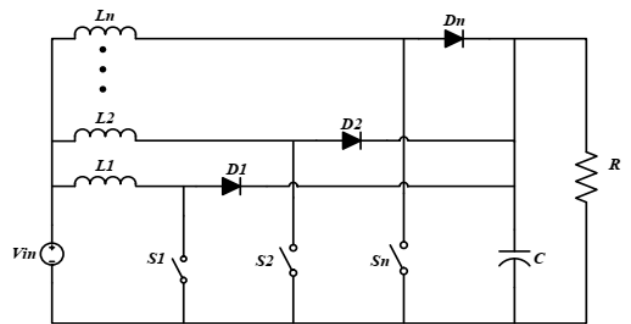

Fig.3: Multi-Phase Boost ConverterIntroduction

Because of the phase difference in the multi-phasing the inductor ripple currents tend to cancel each other, resulting in a smaller ripple current with increased frequency flowing into the output capacitor [9]. The output voltage will be same as that of the conventional converter, but the input inductor current will be reduced by the number of phases.

Multi-phase converters reduce the input and output ripple currents by interleaving the gate pulse for paralleled power stages. With a proper choice of phase number, the output ripple voltage and the input capacitor size can be minimized without increasing the switching frequency.

3.4 Multi-Phase Multi-Stage Boost Converter

By combining the advantages of the Multi-Stage and Multi-Phase Boost converter, a novel topology is structured called Multi-Phase Multi-Stage Boost converter , as shown in figure. Thus, high current at the initial stage is shared due to multiphase and the high static step-up gain is achieved due to multi-stage.

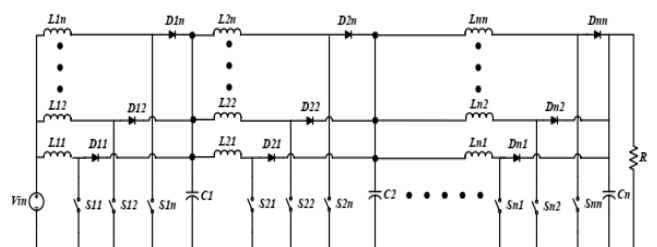

Fig. 4: Multi-Phase Multi-Stage Booster

4. System Design Approaches

A typical boost converter incorporating a feedback loop is described in Figure 5. It is desirable to design this feedback system in such a way that the output voltage is properly controlled and the current or interruptions are unclear to the load. In addition, the reaction system must be stable and, in order to deal with the symptoms, must have state control details such as time and consistency - such as ephemeral overshoot [15, 30]. Therefore, it is necessary to build a circuit that adjusts the duty cycle to achieve the specified output voltage regardless of interruptions and component tolerances. The controller adopts a negative feedback control method to feed the sensed output voltage, which adjusts the duty cycle to a constant output voltage [19, 23].

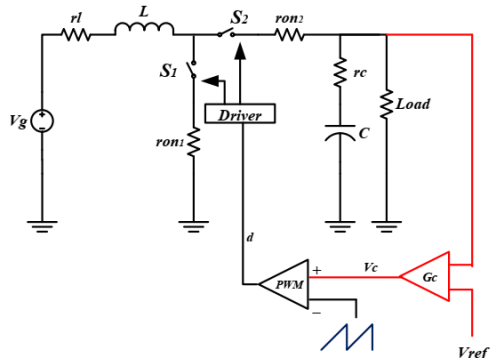

Fig.5: Voltage Mode Controlled Boost Converter

The linear control method can be applied to a linear system, but all switch mode systems are non-linear systems [13-14]. Therefore, the system must be designed as a linear system to implement the linear control method. Small signal AC converter modeling is the process of estimating how low frequency variations in the duty cycle produce low frequency variations across voltages and currents. The AC converter model can be obtained by removing the switching harmonics on average Wave form during changing periods. The average model clearly means that no switching event is visible for the purpose of a continuous signal [22]. Average voltages and currents are, in general, nonlinear functions the converter function consists of a system of wheels, voltages and currents and nonlinear differential equations.

4.1 Small Signal AC Modeling Of Boost Converter

State Space averaging method is approached to have a small signal ac-model of Boost converter. The derivatives of state space variables are expressed as linear combinations of the system independent inputs and state-variables themselves. The physical state variables are the inductor currents and the capacitor voltages [13], [26]. The boost converter is modelled including inductor copper loss i.e. DC resistance of Inductor, Equivalent series resistance (ESR) of filter capacitor and ON resistance of semiconductor switches.

4.1.1 Sub-Interval I

During sub-Interval I, the boost converter is reduced to a linear circuit as shown in Figure 6. The switch is closed, while the switch is open. During this subInterval of switching period, the inductor will store the energy and the capacitor supplies to the load. The derivatives of the state variables are expressed for the reduced linear circuit as shown in Figure 6.

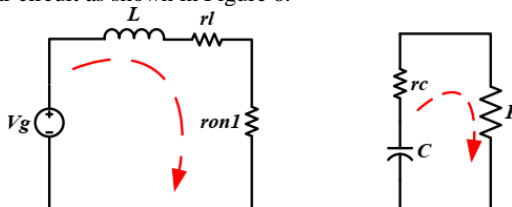

Fig. 6: Sub-Interval I

4.1.2 Sub-Interval II

During sub-Interval II, the boost converter is reduced to a linear circuit as shown in Figure 7. The switch is closed, while the switch

is open. The stored energy in the inductor charges the capacitor and is supplied to the load.

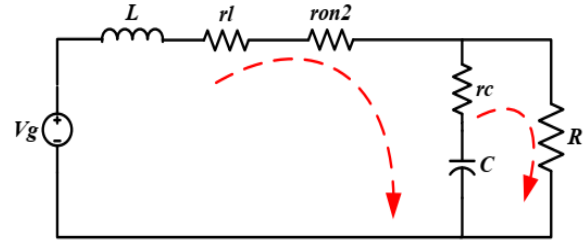

Fig. 7: Sub-Interval II

4.2 Right Half Plane Zero In Boost Converter

From the top control to the output transfer function, the boost converter offers a set of complexities optimal half-plane zero (RHP) in the analysis and features. This is a challenging converter to stabilize when working with voltage mode control. RHP5 causes zero when the booster converter switch is turned on for a long time. Although the control order tries to increase it, the output initially drops to [16, 32]. These are actually features of the classic RHP Zero. An increase in the command signal for the control system causes an initial decrease in the output response. After a constant period of time associated with RHP zero, the output begins to move in the same direction as the control [14]. As a result, if you have a system with RHP zero in control for the output transfer function, you can not expect the control loop to respond quickly to a change of output. For the system to stabilize properly, the bandwidth of the loop must be limited to a frequency less than the frequency of RHP zero [14].

4.3 Compensation For Voltage Mode Boost Converter

Closing the control loop allows the regulator to adjust load interruptions or changes in the input voltage that may adversely affect the output. The optimal compensation of the system allows the band to have bandwidth bandwidth with unconditional stability [19, 32].

4.4 Type III Compensator

In most cases, Type III compensation will replace the network system properly. Board plots suitable for the compensation system have a step margin greater than 20 dB / decade slope, 0 dB crossing at the desired bandwidth 6 and 0 dB crossing [22] less than all frequencies less than 20.

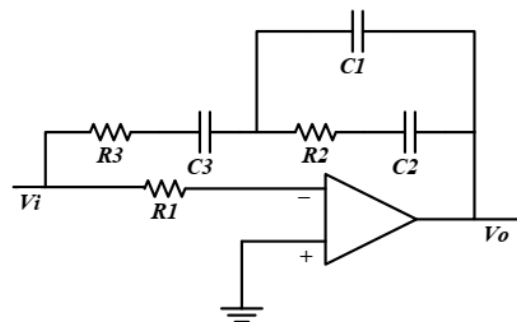

Fig. 8: TYPE III Compensator

Figure 8 shows a generic Type III compensator. The Type III network shapes the profile of the gain with respect to frequency. The Type III Compensation, however, utilizes two zeroes to give a phase boost of . This boost is essential to counteract the effects of an under damped resonance of the output filter at the double pole [18].

5. Results and Discussion

The system is analyzed, designed and simulated in the MATLAB / Simulink program to analyze the various critical outcomes of multi-stage boosters. Based on the Matlab results, the hardware design is considered and the required components must be purchased. This chapter deals with important results in various field analyzes. The transient and frequency frequency responses are analyzed in detail

to understand the behavior of the system under different operating conditions.

5.1 Transient Response

From the timely response of the system, it is clear that the settling time of the system is good, but the transient peaks of inductor currents are very high. This high transient peak current is a threat to the semiconductor switch because the current has its way from the switch to ground. These infections need to be prevented for safe operation. Due to the independent control system for each step, the response error initially reaches its maximum level. A large feedback error then moves the loop filter to its limit, which drives the switching transistor at the maximum rating on the power supply transistor. This condition continues until the output voltage of the power supply reaches its nominal value. Therefore, by using softstart technology, system transient can be avoided. The soft-start circuit reduces this problem, causing the power supply to slow down. The lower rate limits the initial error and reduces the overall drive of the system. The transient response due to load variation is controlled by absorbing the output voltage and feeding it back to the controller, which achieves the task ratio.

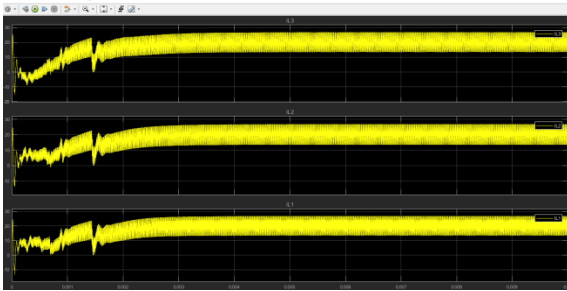

Fig.9: Inductor Currents

5.2 Synchronous Switching

Most DC-DC converters use MOSFET to replace the diode. The advantage of this configuration is that it has a much lower voltage drop than the second MOSFET diode, resulting in a higher circuit capacity. This is especially important in low-voltage, high-current applications. The reason for the power loss in figure 9 is the diode compared to the phosphate. When operating a Schottky diode, it has a voltage of 0.3 to 0.4 V, but has a much lower voltage drop due to single-digit millihoms, such as the MOSFET RDS-ON. This circuit has a control scheme called synchronous switching or synchronous rectification. Two mosfets should not be at the same time to prevent a short circuit at the source, so a "dead time" is created in the switching control - one mosfet will switch off before turning on the other. Two diodes parallel to the MOSFET provide the conductor path to the inductor when the MOSFET is closed. This diode could be a MOSFET body diode or it could be an additional result analysis diode, which is a shortkey diode for better conversion. The synchronous buck converter must operate in constant-current mode because the MOSFET inductor allows it to go negative.

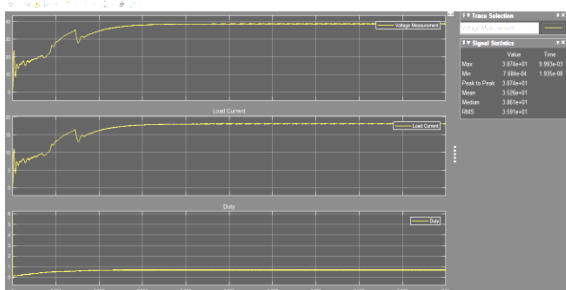

Fig.10: Output Voltage/Current and Duty ratio

The control loop designed for the operating system in continuous

- [1]. O Abdul, R Ahmed. Hardware Implementation of an Adaptive Network-Based Fuzzy Controller for DC-DC Converters, IEEE Transactions on Industrial Applications, Vol. 41, No. 6, 2004, pp. 1557 - 1565
- [2]. M Agostinelli, R Priewasser, S Marsili, M Huemer. Fixedfrequency Pseudo Sliding Mode control for a Buck-Boost DC-DC converter in mobile applications: A comparison with linear PID controller, IEEE International Symposium on Circuits and Systems, ISCAS 2011, 1604 - 1607
- [3]. G AlexanderPerry, F Guang, L Yan-FiePC Sen. A New Analysis And Design Method for Fuzzy Logic Controllers used in Power Converter, Proceedings of IEEE International Conference on Industrial Electronics, IECON', 2005, 1006 - 1011
- [4]. AK Chandra, D Seshachalam, RKTirupathi. New Fuzzy Logic Controller for a Buck Converter, Proceedings of IEEE International Conference on Power Electronics, Drives and Systems, 5, 2006, 1 - 3
- [5]. S Arulsevi, G Uma, V Sampath. Development of Simple Fuzzy Logic Controller for ZVS Quasi-Resonant Converter: Design, simulation and experimentation, Journal of Indian Institute of Science, 86, 2006, 215 - 233
- [6]. JA Asumadu, V Jaganathan. Synthesis of nonlinear control of switching topologies of buck-boost converter using fuzzy logic, Proceedings of the 17th IEEE Instrumentation and Measurement Technology Conference, IMTC 2000, 1, 2000, 169 - 173.
- [7]. C Benjamin Kuo. Automatic Control Systems, Prentice-Hall of India Pvt. Ltd, New Delhi, 2003
- [8]. MK Bourdoulis, JG Spanomichos, AT Alexandridis. Model analysis and intelligent-ANFIS control design for PWM-regulated ac/dc converters, 16th International Conference on Intelligent System Application to Power Systems, ISAP 2011, 1 - 6.
- [9]. H Chaoui, P Sicard, S Miah. Adaptive fuzzy logic control of a DC-DC boost converter with large parametric and load uncertainties, IEEE/ASME International Conference on Advanced Intelligent Mechatronics, AIM 2010, 575 - 580.
- [10]. J Chen, T Zhicheng. T-S fuzzy modelling and control based on BUCK-BOOST converter, 27th Chinese Control Conference, CCC 7, 2008, 312 - 316.
- [11]. X Chen, FL Luo, H Ye. Modified positive output Luo converters, Proceedings of IEEE PEDS 1, 1999, 450 - 455.
- [12]. M Criscione, G Glustolisi, A Lionetto, M Muscara, G Palumbo. A Fuzzy Controller for Step-Up DC/DC Converters, Proceedings of IEEE International Conference on Electronic Circuits and Systems, 2(1), 2001, 977 - 980.
- [13]. A Diordiey, O Ursaru, M Lucanu, L Tigaeru. A hybrid PIDfuzzy controller for dc/dc converters, International Symposium on Signals,Circuits and Systems,SCS1,2003,97 - 100.
- [14]. HR De Azevedo, HL Hey, R Paschoareli, RC Rende. A Fuzzy Logic Controller for Half-Bridge DC-DC PWM ZVZCS Converter to High Power Applications, Proceedings of IEEE International Symposium on Industrial Electronics, 2, 1993, 164 - 169.
- [15]. S El Beid, S Doubabi. Self-Scheduled Fuzzy Control of PWM DC-DC Converters, 18th Mediterranean Conference on Control & Automation, MED 2010, 916 - 921.
- [16]. M Elshaer, A Mohamed, O Mohammed. Smart optimal control of DC-DC boost converter in PV systems, IEEE/PES Transmission and Distribution Conference and Exposition, Florida, 2010, 403 -410.
- [17]. M Elshaer, A Mohamed, OA Mohammed. Smart optimal control of DC-DC boost converter for intelligent PV systems, 16th International Conference on Intelligent System Application to Power Systems, ISAP, 2011, 1 - 6.
- [18]. HW Fang, CQ Lee. Comparison of Fuzzy Logic and CurrentMode Control Techniques in Buck, Boost and Buck-Boost Converters, IEEE Power Electronics Specialists Conference, PESC, 2(1), 1995, 1079 - 1085.
- [19]. G Feng, W Zhang, YF Liu. A New Adaptive Fuzzy Logic Control Method for DC-DC Converter, Proceedings of IEEE International Conference on Industrial Electronics, IECON, 2, 2002, 1208 - 1213.
- [20]. U Fumio, I Takahiro, O Ichirou, S Mamoru. Regulation of Cuk Converters using Fuzzy Controllers, Proceedings of IEEE International Telecommunications Energy Conference, 5, 1991, 261 - 267